



Parks Foundation Brawn Family Foundation Rotary Park Sport Court Mural Call for Artists

Who We Are

Parks Foundation (PFC) is a non-profit organization dedicated to ensuring everyone has a place to embrace their outdoor life. We work directly with communities to bring park and sport projects to life, so that all Calgarians have accessible, unique, recreational, sport and green spaces in their neighborhoods.

The **Brawn Family Foundation Rotary Park** will be the first public community park designed to support youth and adolescent mental health. Parks Foundation's vision is to create an Innovative new park, a sanctuary in the heart of Calgary, that supports community, family and youth wellness. The park will be located just steps from the brand-new child and adolescent mental health centre, **The Summit: Marian & Jim Sinneave Centre for Youth**. The park will be an essential place for families and kids who are receiving vital services and health supports at The Summit. Family doctors and mental health therapists are actually giving green prescriptions, telling people to go out, and be outside as a part of their treatment planning. The purpose of this project is to have a purpose-built green space that is designed in such a way to meet the mental health needs of kids and families. Proposed features of the park include: a shade structure, central flex space, mediation labyrinth, activity area with sport court and bouldering wall, community pathway, and swing benches. Design and construction of the park has been ongoing since summer 2022. With additional funding granted from The City of Calgary, it has made it possible for us to enhance the sport court with an artistic mural.

Information about the Brawn Family Foundation Rotary Park: <https://www.parksfdn.com/brawn>
Information about the Parks Foundation: <https://www.parksfdn.com/>



Artist Call

Parks Foundations is seeking a local artist or muralist to create a vibrant mural on the surface of one semi-circle basketball court in Brawn Family Foundation Rotary Park within the community of Hounsfield Height and Briar Hill, Calgary, Alberta. We are seeking talented artists with creative design skills and mural experience to complete the installation in Spring 2023.

Parks Foundation celebrates the diversity and talent of all artists and welcomes all applicants from BIPOC, Indigenous, LGBTQIAS+, visible minorities and differently-abled communities to apply.

Mural Requirements

The design work shall occur during Winter 2023 and the mural will be installed in Spring 2023. The mural installation will be located outside and all materials and design must be optimized for outdoor use as Calgary weather is always subject to change.

The dimensions of the half court are measured to be 14.80 m x 9.62 m semi-circle half court with an area of 245 m². See figure below. The mural shall be designed and composed to maximize the entire surface of the court while maintaining visibility of all court lines.

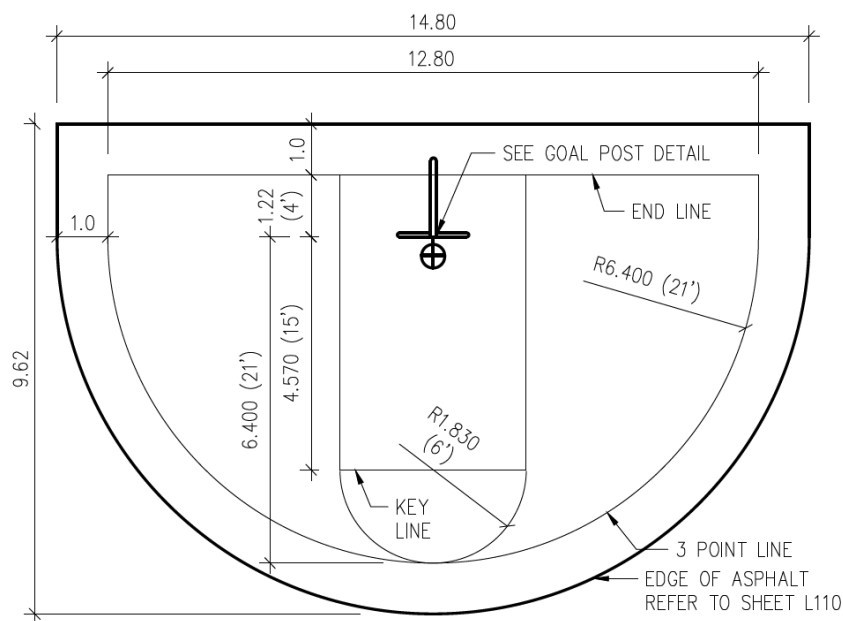

NOTES:

DIMENSIONS ARE IN METRES UNLESS OTHERWISE NOTED.

2m MINIMUM BUFFER AROUND ASPHALT EDGE.

ALL LINES TO BE MASKED AND STRIPED WITH 100% ACRYLIC LATEX PAINT ONLY.

The mural shall be painted using Plexipave, an acrylic mix with Plexipave, or a similar equivalent to meet The City of Calgary's current specifications standards per the *Development Guidelines and Standard Specifications: Landscape Construction*. The selected artist shall work with the sport court



subcontractor to ensure the appropriate medium is being applied. The finished quality of the mural is expected to last nearly the life of a typical sport court surface. Note: The mural shall not be painted with interior or exterior wall or road paint that does not meet the sport court specifications.

Artist Requirements & Scope of Work

Qualified artist(s) applying shall:

- Have demonstrated experience installing medium to large scale murals on exterior surfaces.
- Demonstrated artistic and creative design skills for concept, composition, colour, and form.
- Experience working with sport court surfacing material (Plexipave or similar equivalent) will be considered an asset but not a requirement.
- Reside in Alberta and be available in Calgary, Alberta during the mural installation.

Upon being selected, the artist must:

1. Be available immediately to attend in-person and/or virtually for design and coordination meetings with PFC, consultants, and the contractors as required;
2. Develop a Mural Artwork Design Concept
 - A. Provide a concept sketch of the mural design for review and approval by PFC;
 - B. Provide an installation plan, including recommended method for transferring artwork to the asphalt surface;
 - C. Provide concept description and rationale.
3. Mural Installation

The installation of the mural can be completed under two possible scenarios.

(a) The artist shall undertake the mural installation, where the selected artist has demonstrated previous experience with sport court surfacing installation and has indicated that they wish to complete the installation of the mural themselves.

(b) The sport court subcontractor shall undertake the mural installation, where the selected artist does not have previous experience installing sport court surfacing or has indicated they wish to only to provide the mural artwork. The artist shall work collaboratively with the contractors to ensure the integrity of the artist's concept is executed according to the approved concept and vision.

A. Artist to Undertake Mural Installation

- In this scenario the artist has more creative freedom to develop a design concept that can contain more complex figures and shapes.
- Provide a cost estimate of supplies and equipment required for the work;
- Provide a schedule for installation;
- Be available and prepared to install the mural in Spring 2023 during the ongoing construction and completion of the Brawn Family Foundation Rotary Park;
- Secure all necessary supplies and equipment ahead of mural installation;
- Start and finish the mural painting over a consecutive 8-14 days starting as soon as the construction of the asphalt base for the basketball court is complete by the sport court subcontractor (exact timing shall be dependent on weather, site conditions and coordination of other subtrades with the Prime Contractor);



- Work collaboratively under the supervision of the Prime Contractor and subcontractors on site.
- Artist is responsible for providing and wearing all appropriate personal protective equipment as required by the Prime Contractor, including but not limited to high-visibility safety vest, steel toed boots, safety glasses, ear protection, paint masks, coveralls, etc., as required.
- Sport court subcontractor shall provide an asphalt base with single standard colour base coat and court line painting.

OR

B. Sport Court Subcontractor to Undertake Mural Installation

- In this second scenario, the artist will be able to develop a design concept that is limited to only geometric shapes and lines. Complex shapes and figures will not be able to be accomplished by the sport court subcontractor.
- In collaboration with the contractor, provide an installation plan, including recommended method for transferring artwork to surface;
- During the mural installation by the subcontractor, the artist shall work in collaboration to provide oversight to ensure artwork is executed accurately to the approved concept.
- Be available and prepared to be on site regularly during the mural installation over a consecutive 8-14 days (exact timing shall be dependent on weather, site conditions and coordination of other subtrades with the Prime Contractor);
- Work collaboratively under the supervision of the Prime Contractor.

Compensation

Artist fee will be determined upon the selection of the artist and whether the installation of the mural will be undertaken by the artist, themselves, or by the sport court subcontractor.

- A. For an artist developing ONLY the mural artwork, the artist's fee shall be up to \$10,000. This includes work for:
 - The approved mural artwork
 - Regular on-site mural installation oversight
 - Note: Materials, equipment, and installation cost shall be supplied by the sport court subcontractor.
- B. For an artist undertaking the mural installation and developing the mural artwork, the artist's fee shall be up to \$35,000. This includes work for:
 - The approved mural artwork
 - Artist to supply their own materials & equipment (can be coordinated with subcontractor)
 - Artist to undertake their own forces to install the mural.
 - Note: the sport court asphalt base, a single coat colour, and court line painting shall be provided and prepared by the sport court subcontractor.



Compensation will be determined and agreed upon by the artist and PFC upon the selection of the artist and the signing of PFC's *Contracting Services Agreement*.

The artist shall provide invoices upon the completion of the following milestones:

1. Approval of Design Concept 30% of artist fee
2. Completion of Mural Installation 70% of artist fee

Proposal Submission Requirements

Length: Maximum **six** 8.5 x 11 pages (not including an optional cover page)

Size: 10 MB maximum

File type: Submissions should be in a single combined PDF file.

File name: Submissions should clearly indicate your name. Please use the following format for your file "PFC_Mural_FULLNAME.pdf"

Proposals shall comprise of:

- Artist Profile Information
- Artist Practice Details
- Artist Portfolio
 - A selection of demonstrated and applicable projects or works with descriptions, (who, where, when, completion status)
 - Indication of whether the work was independent or a collaboration and what role the artist was involved in.

Artist Profile Information (1 page maximum)

Provide your:

- legal name(s), preferred name(s),
- email,
- phone number,
- address (including current residing City),
- artists' website, if available;
- artists' social media (i.e. Instagram) information, if available;
- Optional: Please include pronouns and how you identify (i.e.: Indigenous, person of colour, LGBTQIAS+, differently abled etc., including as much detail as you are willing to share)
- Indicate whether the artist intends to:
 - ONLY develop the mural artwork
 - OR
 - develop the mural artwork AND undertake the mural installation.

Artistic Practice (1 page maximum)



A written description of your artistic practice with details on your artistic process, styles, influences, subject matter, chosen mediums and any focus outside of muralism. Please describe any art or design education training, apprenticeship, or related field.

A written description of your experience with murals, both interior and exterior if applicable. Describe the timelines and sizes of the murals you have painted, referencing images in your portfolio. Alternatively, describe your experience with other forms of painting or art if you are newer to muralism.

Artist Portfolio (*4 pages maximum*)

A selection of demonstrated and applicable projects or works with photographs and/or illustrations and brief descriptions (i.e. where, when, completion status, size, medium/materials, client if applicable).

Each selected work shall clearly and concisely indicate whether the work was completed independently or as a collaboration. For any collaboration works, describe the role(s) in which the artist was involved in (i.e. conception of artwork, led installation vs assisted with installation, mentor vs mentee, etc.)

Application deadline: March 8th, 2023, at 4:00 pm MST

Email your portfolio application submission to info@parksfdn.com

Subject line to include “*Brawn Park Mural Artist Call Submission – Full Name*”

Each applicant is solely responsible for ensuring that their application is received at Parks Foundation before the specified deadline. Late submissions may not be considered.

Please email all questions to info@parksfdn.com

Subject line to include “*Brawn Park Mural Artist Call – Inquiry*”

Estimated Timeline

Application Deadline: Wednesday, March 8th, 2023 at 4:00 pm MST

Artist Selection: March 14th, 2023

Mural Concept Development: March 30th, 2023

Mural Installation: April 15th – May 30th, 2023
(*TBD subject to weather & construction schedule timing*)